



DRUM DRYER

 **KATSURAGI INDUSTRY CO.,LTD.**

HEAD OFFICE 5-4-6 MINAMI-TSUMORI NISHINARIKU,
OSAKA, 557-0063, JAPAN
TEL.+81-6-6659-2432
FAX.+81-6-6658-3789

<http://www.katsuragi.co.jp/>



 **KATSURAGI INDUSTRY CO.,LTD.**

KATSURAGI DRUM DRYER

Introduction

Drum drying is a way to obtain dried materials directly from solution or slurry (solid suspension). This drying method is applied widely in various fields such as chemicals, pharmaceutical products, food, dye, and waste water treatment. In its basic operation, a liquid is fed on a rotary drum heated with steam supplied inside; its liquid film is attached on the drum surface; and while the drum turns, including water in the film is evaporated rapidly.

Dried materials are continuously scraped from the drum surface with a fixed knife easily.

Characteristic

1. Operation is continuous, allowing products of stable quality.
2. Drying time is short, making material which is sensitive to heat possible to dry well.
3. Drum dryer is the device which is rational in most to perform evaporation and drying at the same time.
4. Because drum dryer is a heat transfer drying system, its thermal efficiency is better than that of the other type of dryers and it is very economical.
5. Because no liquid is left inside at shutdown, processing is possible to the last one drop.
6. Performance adjustment is easy to carry out, allowing one person to manage plural units.
7. Cleaning in the dryer is simple, making the handling liquid change easy.

Types

Double Drum Dryer

Main parts of this system are two drums, which are heated with steam by the inside and rotate.

As for two drums, a feed-box is made between the drums facing each other and two end-boards attached to this drum ends, and raw liquid is sent here (cf. cross section).

Gap between the drums can be adjusted even during rotation. Raw liquid supplied in the feed-box is evaporated and concentrated therein, passed through the appropriately adjusted gap between the drums, scraped with the knives mounted to the upper part of the drums respectively, then collected in one area through conveyor. Vapor generated is collected in the hood covering the upper part of the drums to discharge through the exhaust duct.



Double Drum Dryer $\phi 1,600 \times 4,000L$

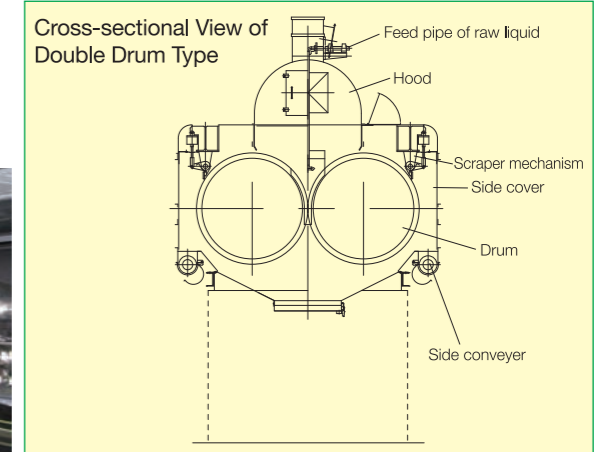

Vacuum Drum Dryer

This Vacuum Drum Dryer can answer the following demand.

- (1) Products should be dried at low temperature as much as possible.
- (2) Evaporated vapor, which is organic solvents, should be collected.



Feed type

Double Drum

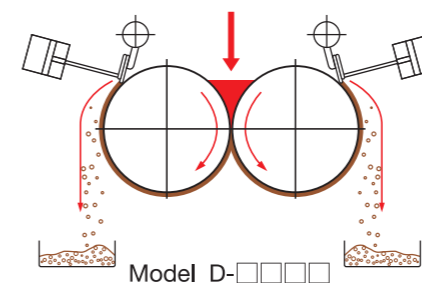

Model D-□□□□

Twin Drum

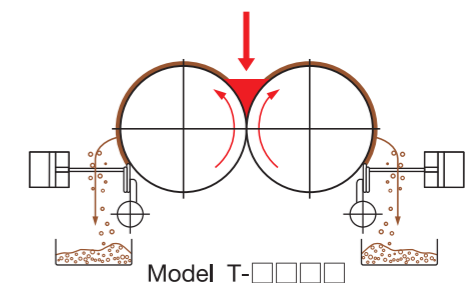

Model T-□□□□

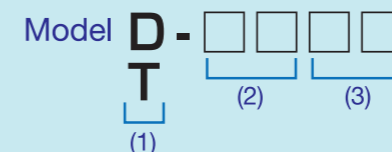

(1) D... Double Drum
T... Twin Drum

(2) Drum diameter

(3) Drum length

If the Vacuum Drum Dryer is the VD-□□□□ model will be

Types

Single Drum Dryer

This system has a single drum, which are heated with steam by the inside and rotate. In many cases, this is used for those to which the Double Drum Type is not suitable.

(a) Roll-feed type Single Drum

Raw liquid is fed between the drum and the feed roll to form a film on the drying drum surface. Feed roll may be increased the number of rolls to two or three according to the dried material demand.

(b) Dip-feed type Single Drum

In this system, a shallow bowl-like liquid tank is provided below the drum. Raw liquid is fed in this tank. Drum is dipped in the fluid, which is stuck on the drum surface. In the liquid tank, an agitator is provided to prevent precipitation of solid and to keep the liquid density constant.

(c) Splash- or Spray-feed type Single Drum

A liquid tank is placed below the drum to feed the raw liquid, which should be kept constant. In splash-feed type, liquid is splashed to stick on the drum with rotary wings mounted in the liquid tank. In spray-feed type, raw liquid is sprayed to stick on the drum surface by a spray nozzle.



Single Drum Dryer with dual-roll
(Waste water drying system)
φ1,000 x 1,500L

Standard Dimension Size

Double Drum Dryer

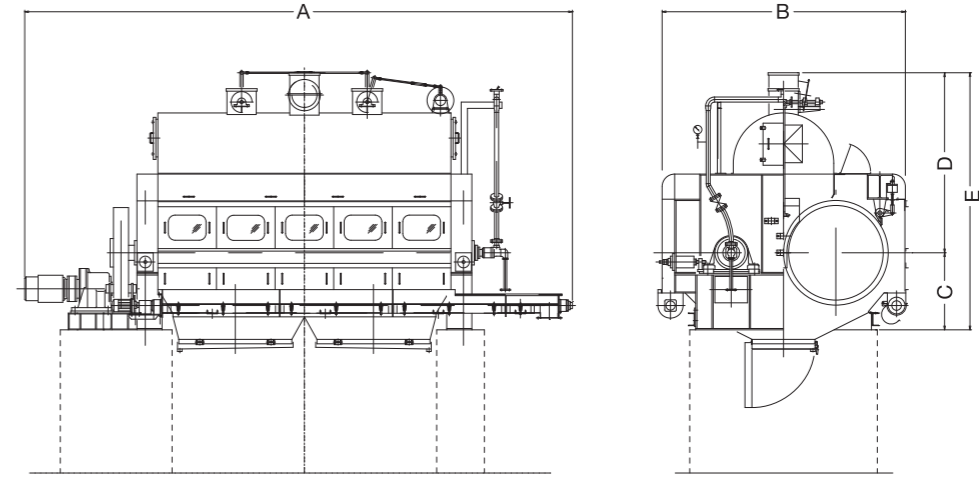

Double-Drum Dryer Standard Dimension List

Model	Drum size [mm]		Heating area [m ²]	Power [kW]		Outer size [mm]					Steam inlet size [A]
	Diameter	Length		Unit body	Side conveyer	A	B	C	D	E	
D-0405	400	500	1.25	0.75	—	2,000	1,000	500	850	1,350	25
D-0410	400	1,000	2.5	1.5	—	2,500	1,000	500	850	1,350	25
D-0610	600	1,000	3.7	2.2	0.4	3,450	1,650	850	1,200	2,050	40
D-0615	600	1,500	5.6	2.2	0.4	4,000	1,650	850	1,200	2,050	40
D-0815	800	1,500	7.5	5.5	0.4	4,300	2,150	770	1,350	2,120	50
D-0820	800	2,000	10	5.5	0.4	4,950	2,150	770	1,350	2,120	50
D-1020	1,000	2,000	12.5	7.5	0.4	5,050	2,500	840	1,500	2,340	65
D-1025	1,000	2,500	15.7	7.5	0.4	5,550	2,500	840	1,500	2,340	65
D-1225	1,250	2,500	19.6	11	0.75	5,800	3,000	930	1,770	2,700	65
D-1230	1,250	3,000	23.5	11	0.75	6,300	3,000	930	1,770	2,700	65
D-1530	1,500	3,000	28.2	15	0.75	6,450	3,500	1,000	2,160	3,160	80
D-1535	1,500	3,500	33	15	0.75	6,950	3,500	1,000	2,160	3,160	80

Maximum steam pressure : 0.8 MPaG

Feed type

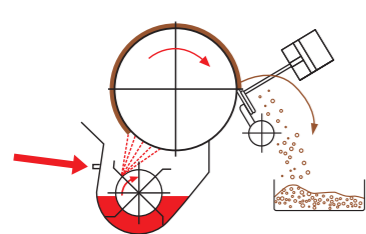

Splash-feed type
Model S-□□□□-SP

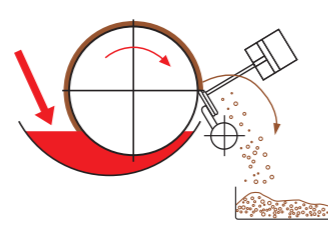

Dip-feed type
Model S-□□□□-DP

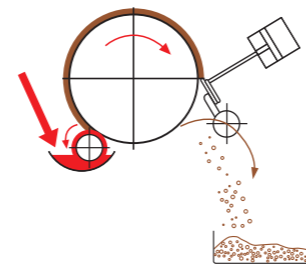

Below roll feed type
Model S-□□□□-BR

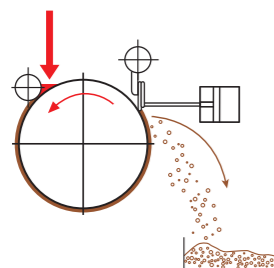

Top roll feed type
Model S-□□□□-TR

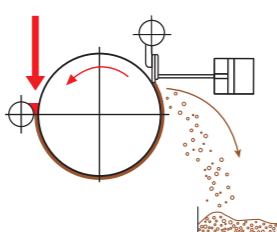

Side roll feed type
Model S-□□□□-SR

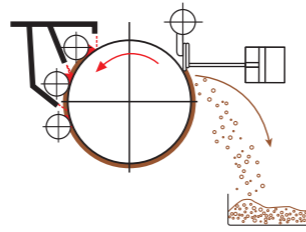

Multi-roll feed type
(Three-stage roll)
Model S-□□□□-MR

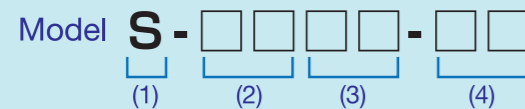

- (1) S...Single Drum
- (2) Drum diameter
- (3) Drum length
- (4) Feed system

Capacity Cases

Examples of Performance

Treated materials	Type	Fluid feeding Means	Water content % (W.B.)		Steam pressure [MPaG]	Drum rotation speed [rpm]	Temp. of raw liquid °C	Treatment performance of raw liquid kg/m ² hr	Drum size φmm x L mm
			* (1)	* (2)					
Beer yeast	Double	Center	85	8	0.5	5	80	50	1,500 x 3,500
Starch	Single	Multi-phased roll	65	5	0.4	1.8	50~60	27	1,500 x 2,700
Orange pulp	Double	Center	88	6	0.6	2.5	Room temp.	48	800 x 1,500
Defatted soybean cake	Double	Center	82	7	0.7	3	Room temp.	40	1,250 x 3,000
Shochu distillation residue	Double	Center	84	7	0.7	1	85	30	1,500 x 3,500
High polymer coagulant	Single	Roll/Slit	40	5	0.2	0.3	Room temp.	7	1,500 x 3,500
Extract (chicken)	Double	Center	50	8	0.4	4	60	25	1,250 x 3,000
Fish breeding fodder	Double	Center	90	5	0.5	3.8	Room temp.	55	600 x 1,500
Ion-exchange resin waste water	Double	Center	90	3	0.5	2.5	Room temp.	50	900 x 1,800
Tofu refuse	Double	Center	84	9	0.7	1.5	30~40	27	400 x 600
Pharmaceutical products	Double	Center	95	8	0.4	4	Room temp.	35	1,250 x 3,500

* (1), Undiluted solution * (2), Products

Examples of actual results

We have the many actual results of drum dryer. Especially for the following products, drum dryers are used conspicuously.

- 1) Beer yeast, pulp yeast, and microbial cell-related products
- 2) Animals or plants extract products
- 3) Special dye and high polymer compounds
- 4) Slurry or solution of inorganic/organic materials
- 5) Industrial waste water
- 6) Others

Example of flow sheet for a drying system using Drum Dryer

Drum Dryer for α -starch

In producing α -starch, many of drum dryers made by FC(cast iron) are used. We have come up with special devices for the drum dryers for α -starch to supply to the customers.

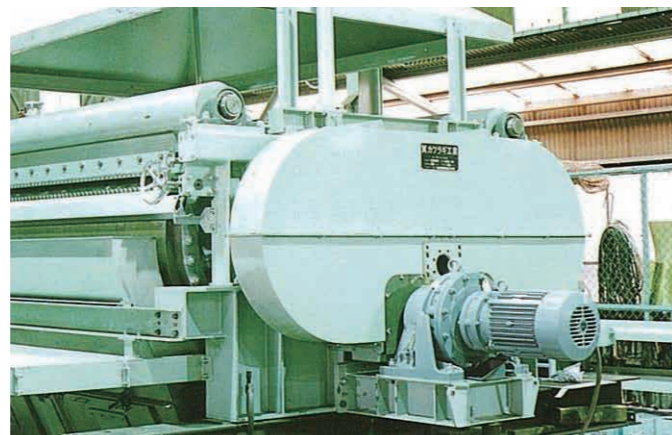

Double-Drum Dryer for α -starch: ϕ 1,250 x 3,000L

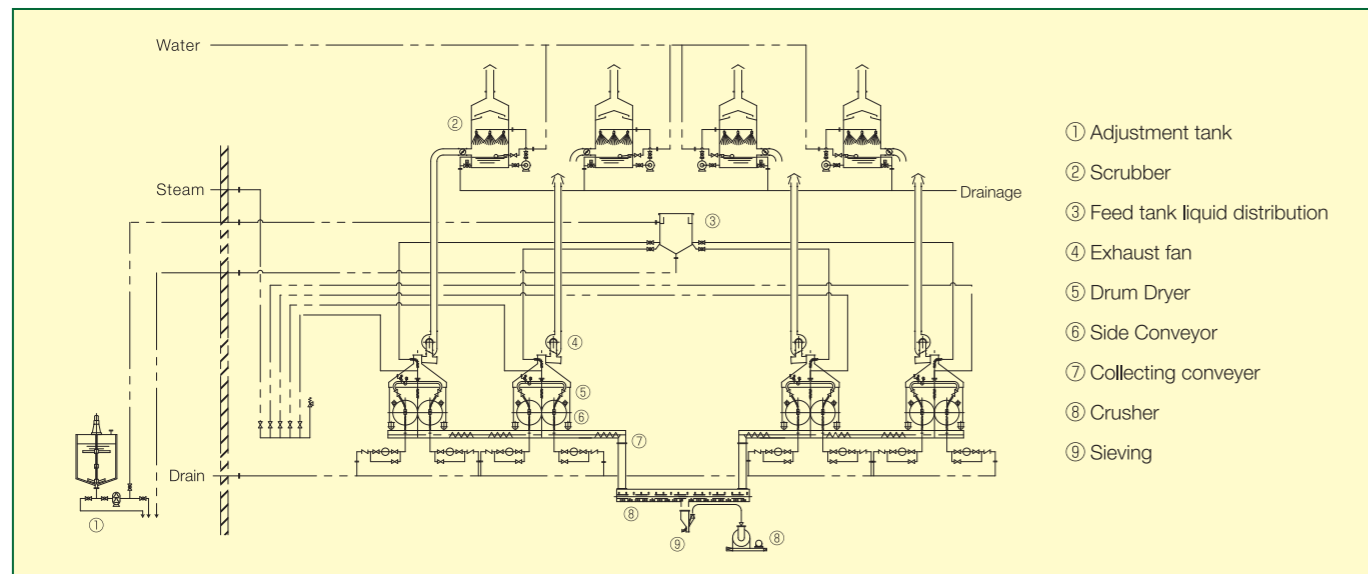

Shochu residue waste water treatment system

Provided with the process in which distillation residue is concentrated with our unique concentrator, then dried with the Double Drum Dryer.

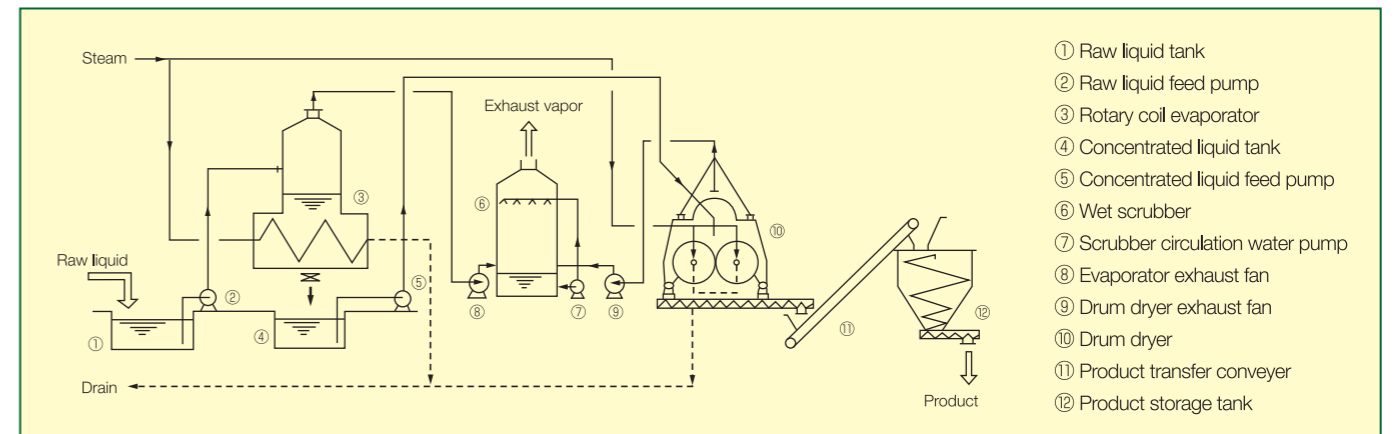

Defatted soybean protein sterilizing & drying system

Provided with the process in which raw material is dehydrated to some extent with Double-drum Dryer, then dried by flash drying to obtain products.

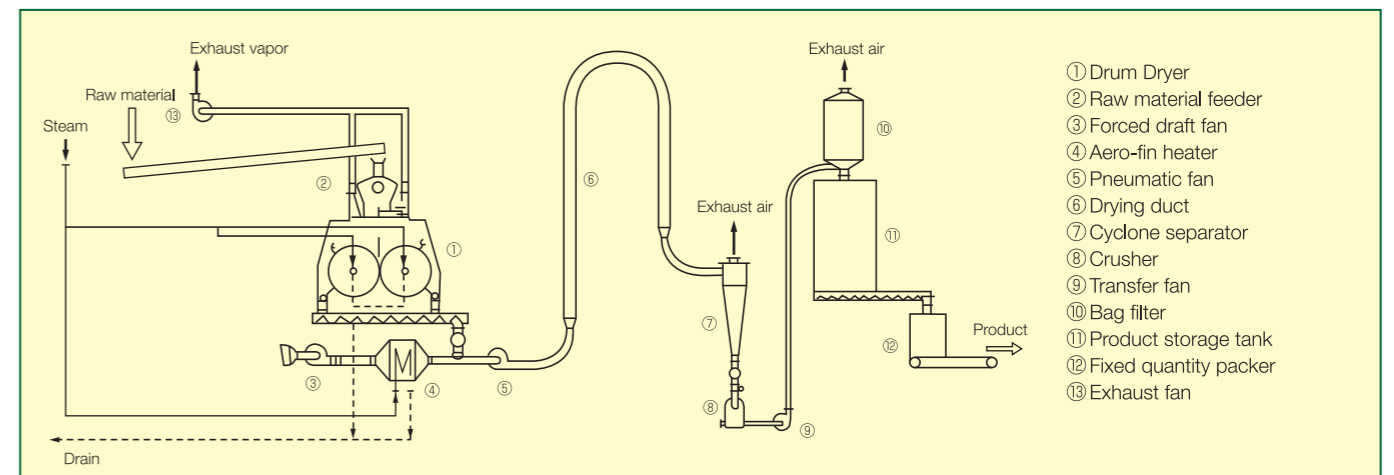

Test machines

The Drum Dryer has to confirm the property of the treated materials by all means using a test machines. We have test machines always available, of which specifications are indicated below, and we are ready to carry out a test as needed and present the plan of equipment.

- 1) Dimensions : Drum size: ϕ 400 x 500L
Total surface area (Double Type): 1.25 m²
- 2) Material : Drum: SS41 + hard chromium plate
Other main parts: SUS 304
- 3) Type : Double, Twin, and Single Type, any of which is available to test.

